



EJERCICIO 7:

PLANTA DE ACABADOS

Ejercicio: En 1 formato A-2 de papel mantequilla o calco elabore el plano de acabados utilizando como referencia las siguientes planillas y la nomenclatura de los formatos que aparecen a continuación. En un formato posterior indique los detalles de puertas y ventanas como se indica en este documento.

NOMENCLATURA DE ACABADOS	
	INCIDA TIPO DE VENTANA INDICA ALTURA DE SILLAR INDICA ALTURA DE SILLAR
	CIELO REPELLO + CERNIDO REMOLINEADO
	PISO CERAMICO DE 44 CM* 44 CM
	PUERTA TIPO I
	REPELLO + CERNIDO VERTICAL
	TORTA DE CONCRETO
	PISO ANTIDESLIZANTE
	INDICA GRAMA
-----	INDICA AZULEJO A 1.60 MT EN DUCHA Y 1.20 MT EN AREA DE INODORO Y LAVAMANOS Y EN COCINA INICIA A 1.20 MT Y TERMINA A 1.60 MT

PLANILLA DE PUERTAS				
TIPO	CANTIDAD	ANCHO	DINTEL	OBSERVACIONES
	1	5.05	2.10 mts.	Metal
	1	1.40	2.10 mts.	Madera
	7	0.90	2.10 mts.	Madera
	4	0.70	2.10 mts.	Madera
	1	1.00	2.10 mts.	Madera
	5	0.80	2.10 mts.	Madera
	1	0.70	2.10 mts.	Madera
	1	1.40	2.10 mts.	Madera
	1	2.00	2.10 mts.	Madera
	1	1.00	2.10 mts.	Madera

PLANILLA DE VENTANAS					
TIPO	CANTIDAD	ANCHO	DINTEL	SILLAR	OBSERVACIONES
	2	1.20	2.10 mts	1.40	MARCOS DE ALUMINIO VIDRIO DE 5 mm.
	1	1.00	2.10 mts	1.00	MARCOS DE ALUMINIO VIDRIO DE 5 mm.
	1	1.50	2.10 mts	1.00	MARCOS DE ALUMINIO VIDRIO DE 5 mm.
	2	0.70	2.10 mts	1.00	MARCOS DE ALUMINIO VIDRIO DE 5 mm.
	4	1.00	2.10 mts	1.70	MARCOS DE ALUMINIO VIDRIO DE 5 mm.
	2	1.50	2.10 mts	0.40	MARCOS DE ALUMINIO VIDRIO DE 5 mm.
	1	0.45	2.10 mts	1.20	MARCOS DE ALUMINIO VIDRIO DE 5 mm.
	1	2.00	2.10 mts	0.40	MARCOS DE ALUMINIO VIDRIO DE 5 mm.
	1	0.70	2.10 mts	1.00	MARCOS DE ALUMINIO VIDRIO DE 5 mm.
	2	0.70	2.10 mts	1.70	MARCOS DE ALUMINIO VIDRIO DE 5 mm.
	1	0.75	2.10 mts	1.70	MARCOS DE ALUMINIO VIDRIO DE 5 mm.

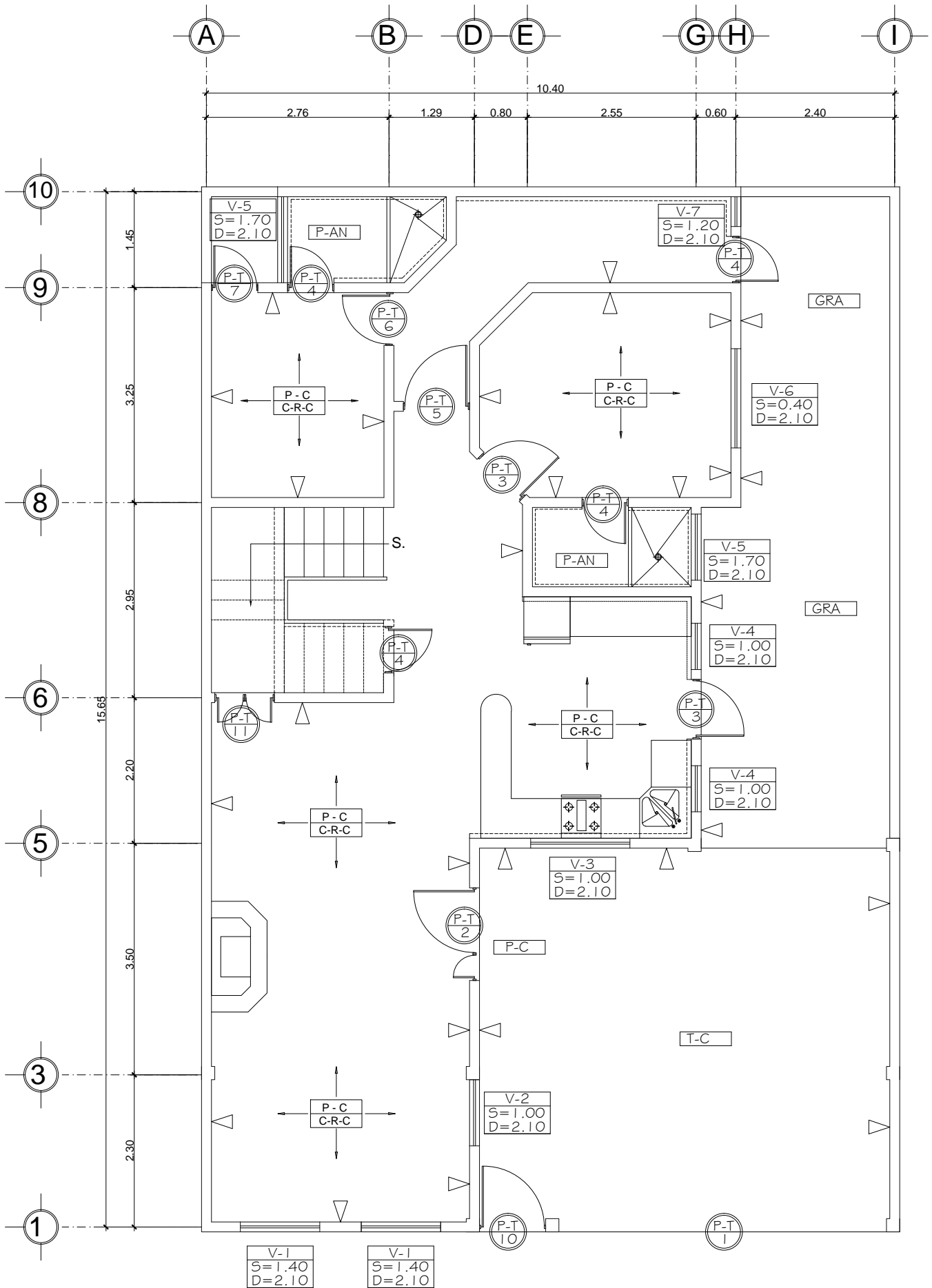

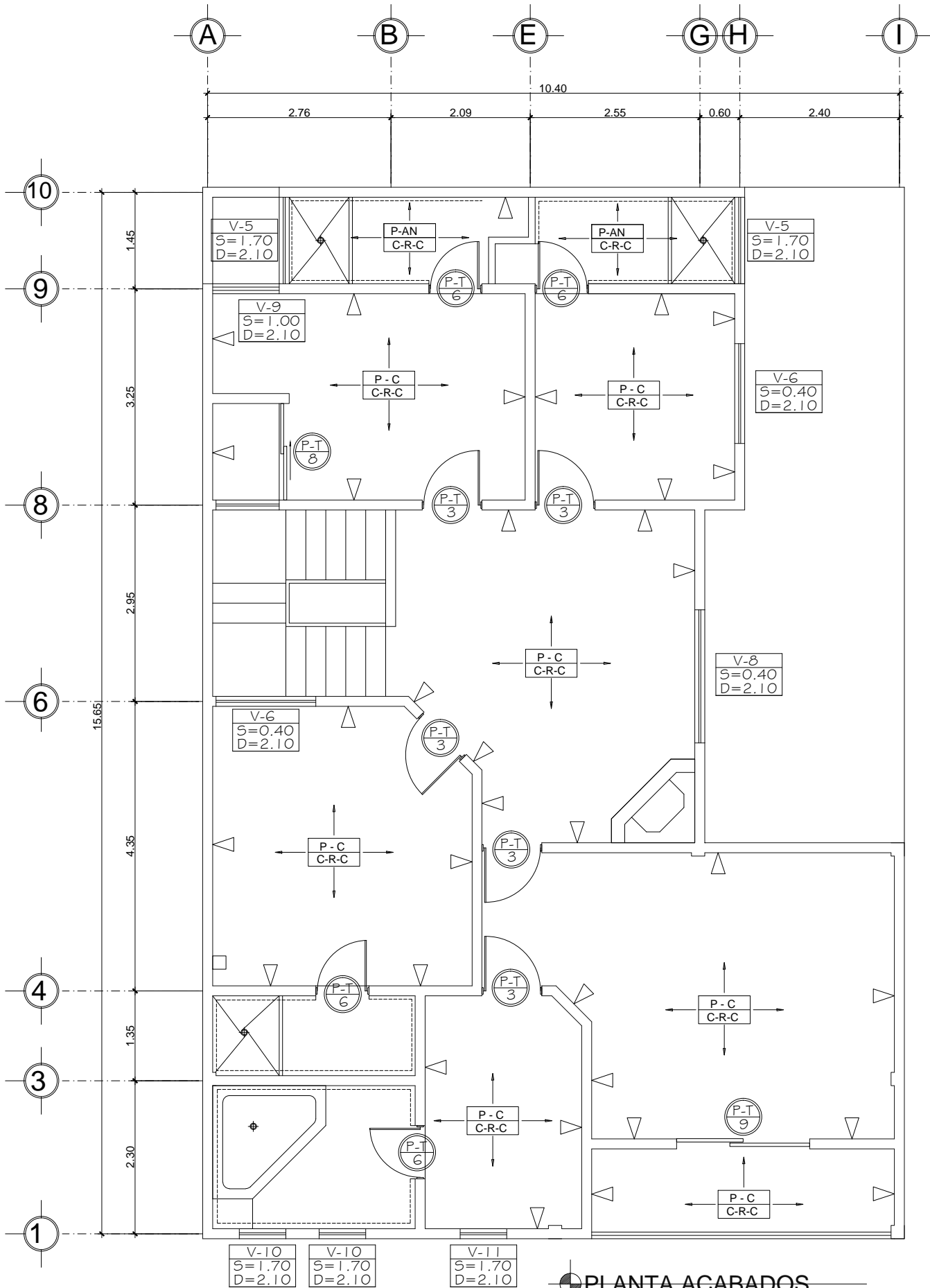

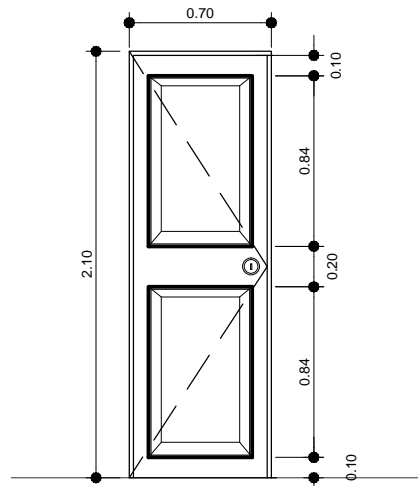

Puerta Tipo P-4

Madera 4 Unidades

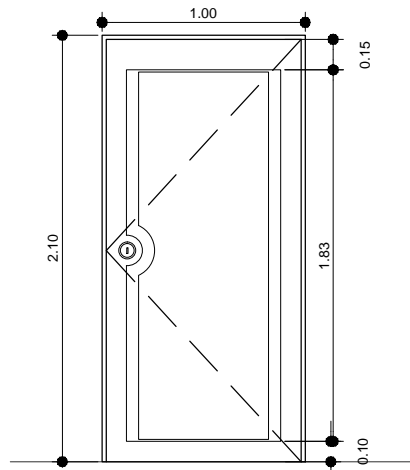

Puerta Tipo P-5

Madera 1 Unidades

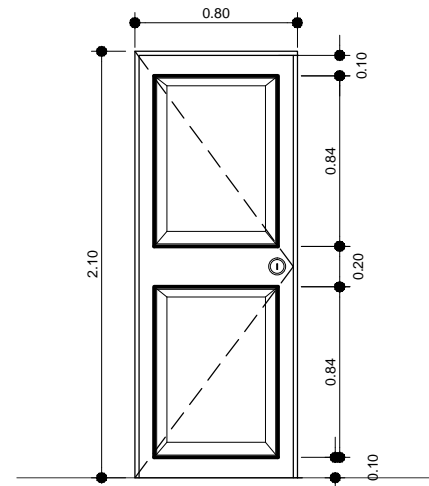

Puerta Tipo P-6

Madera 5 Unidades

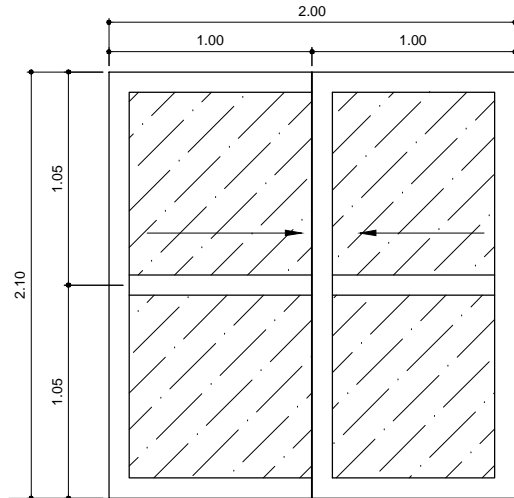

Puerta Tipo P-9

Madera 1 Unidades

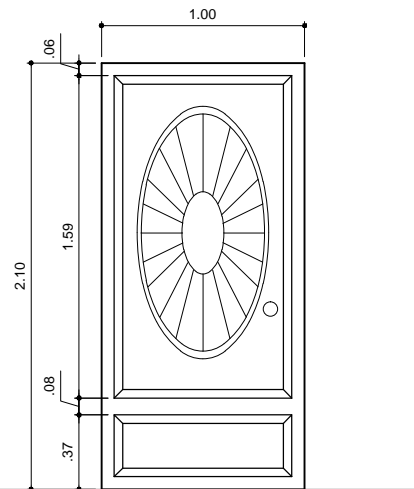

Puerta Tipo P-10

Madera 1 Unidades

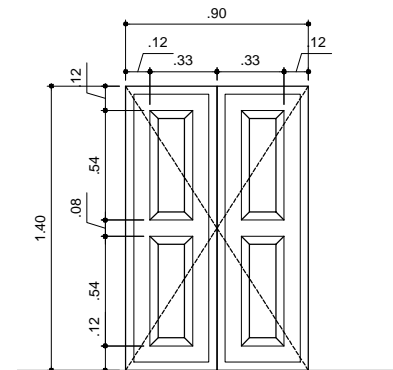

Puerta Tipo P-11

Madera 1 Unidades

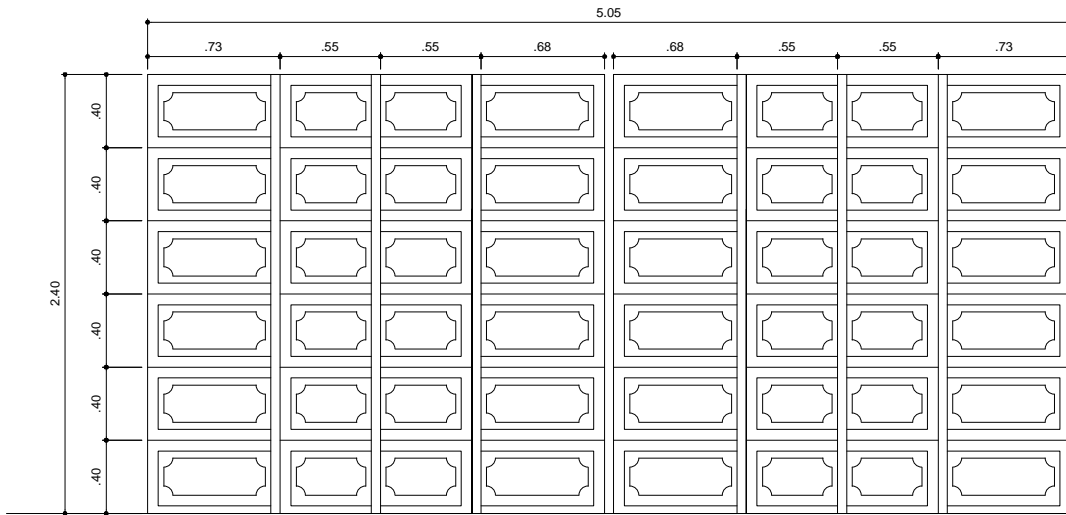

Puerta Tipo P-1

Metal 1 Unidad

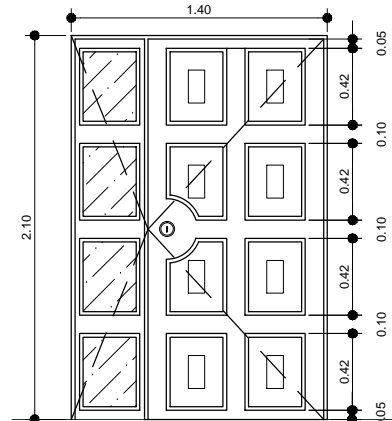

Puerta Tipo P-2

Madera 1 Unidad

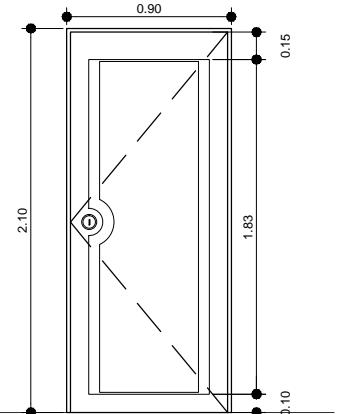

Puerta Tipo P-3

Madera 7 Unidades

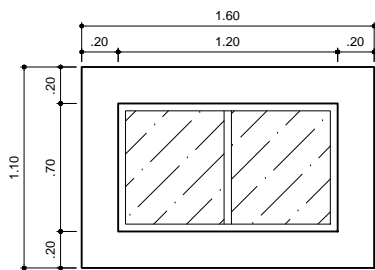

Ventana Tipo V-1

Aluminio 2 Unidad

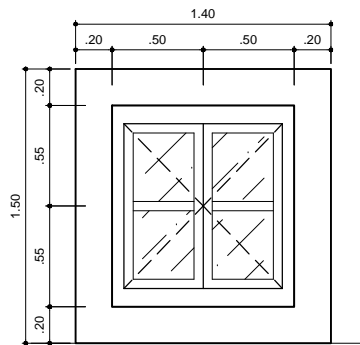

Ventana Tipo V-2

Aluminio 1 Unidad

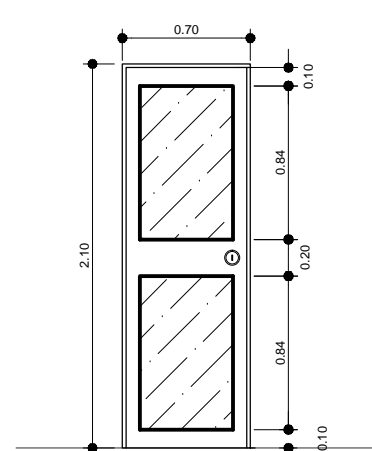

Puerta Tipo P-7

Madera 1 Unidades

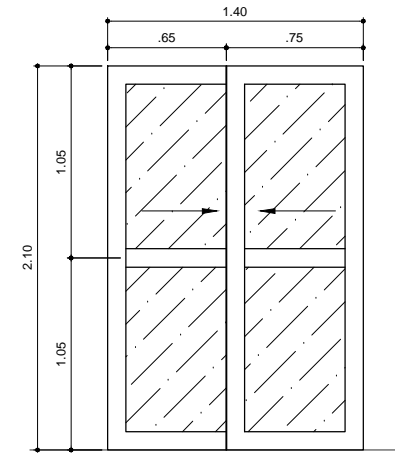

Puerta Tipo P-8

Madera 1 Unidades

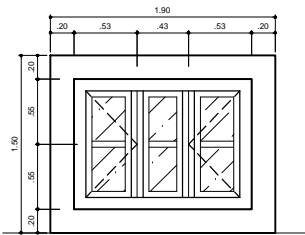

Ventana Tipo V-3
Aluminio 1 Unidad

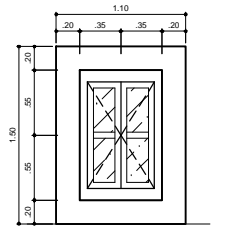

Ventana Tipo V-4
Aluminio 2 Unidad

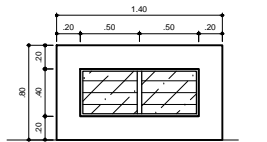

Ventana Tipo V-5
Aluminio 4 Unidades

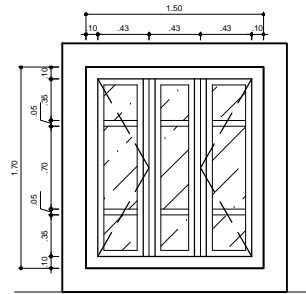

Ventana Tipo V-6
Aluminio 2 Unidades

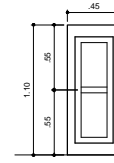

Ventana Tipo V-7
Aluminio 1 Unidad

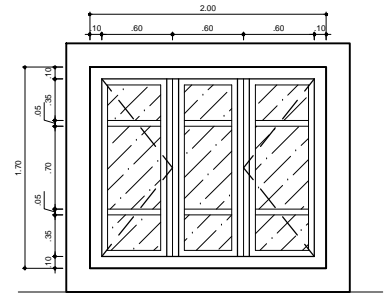

Ventana Tipo V-8
Aluminio 1 Unidades

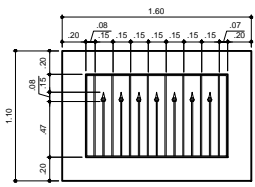

Balcon de Ventana Tipo V-1
METAL 2 Unidad

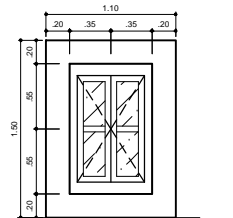

Ventana Tipo V-9
Aluminio 1 Unidad

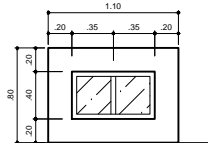

Ventana Tipo V-10
Aluminio 2 Unidad

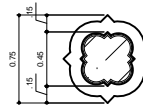

Ventana Tipo V-11
Aluminio 1 Unidad

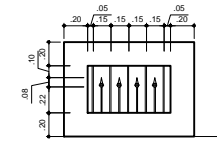

Balcon de Ventana Tipo V-10
METAL 2 Unidad